

TRIVEX Inc.

TRIVEX PLUS 70
PRODUCT DESCRIPTION

This manual describes the Trivex PLUS 70 product line and contains information needed by those who plan, install, and program Trivex equipment.

REV. H

TABLE OF CONTENTS

<u>SECTION</u>	<u>PAGE</u>
PLUS 70 System Description	1
3270 Compatibility	1
System Components	1
Remote Controller	1
Local Controller	1
System Compatibility	1
Device Adapter	1
Display Stations	2
Keyboards	2
Printers	3
Stand Alone Display Station	6
Mini Cluster Display Station	7
Configurations	8
Local System	8
Remote System	9
Features	10
Standard	10
Optional	11
PLUS 70 System Operation	12
Display Operation	12
Formatted	12
Unformatted	12
Keyboard Operations	13
Cursor Positioning Controls	13
Editing Controls	13
Erasing Controls	14
Printer Operation	14
Buffered 80 CPS, 165 CPS, 125 LPM	14
End of Message and New Line	14
Forms Control	15
Error Conditions	15
Local Display Print	15
PLUS 70 System Test Features	16
Status Reports	16
Plus 70 Display Station Test Features	17
Plus 70 Controller Test Features	18
Plus 70 Printer Test Features	18
PLUS 70 Remote System Maintenance Aid Program (MAP).	19
Appendix 1 (Indicators)	A1
Appendix 2 (Status Display) Remote	A2
Status Display Local	A6

TABLE OF CONTENTS

<u>SECTION</u>	<u>PAGE</u>
Appendix 3 Controller Special features	A18
Transaction Statistics	A19
Prompting Line	A-22
.	

PLUS 70 SYSTEM DESCRIPTION

3270 Compatibility

The PLUS 70 Information System is composed of Display Stations, Keyboards, Printers, and Controllers, each operating under independent program control. Each component is completely compatible and is interchangeable with the equivalent component of the IBM 3270 Information Display System. The PLUS 70 Display System is the most flexible display system presently available.

SYSTEM COMPONENTS

1. Remote Controller (0712)

Interchangeable with the IBM 3271 Control Unit, interfacing to the 360/370 Data Processing System via modems, or to a Transmission Control Unit (TCU) via a special modem cable. The 0712 Controller interfaces via Binary Synchronous Communication (BSC) data link mode, operating in half duplex mode, using half duplex or full duplex facilities at transmission speeds from 300 BPS to 19,200 BPS, which are switch selectable within the Controller.

The 0712 Controller has the following indicators:

CTS Wait	Selected
System Ready	Transmit
Sync Search	Status

The 0712 Controller is 15" wide x 22" high x 20" deep, and may operate on a 115V, 208V or 230V, 50/60 Hz power source, 250 watts.

2. Local Controller (0722)

Interchangeable with the IBM 3272 Control Unit, providing external interface to the 360/370 Data Processing System. The standard 0722 Controller can service up to 8 Display Stations and/or Printers. The 0722 can support up to 32 PLUS 70 Display Stations and/or Printers with additional Device Adapters. Data transfer rates allow operation at channel speed to reduce response time. The 0722 attaches to the 360/370 system via a selector, multiplexer, or block multiplexer channel, using existing channel cables. The 0722 Controller is 28.5" wide x 34" high x 19" deep, and may operate on a 115V, 208V or 230V, 50/60 Hz power source, 250 watts.

3. System Compatibility

- (a) The PLUS 70 is fully compatible with all IBM systems, operating systems, and applications software supporting the 3270.
- (b) Trivex Display Stations can be attached to System 3 Models 8, 10, 12 and 15, they may also replace 3277 Displays in the 3790 System.
- (c) Existing IBM cables may be used.

4. Device Adapter (020)

The basic 0712 or 0722 Controller can operate up to 8 Display Stations, and/or Printers; additional Display Stations and Printers require an 020 Device Adapter. The Adapter provides the facilities necessary to service up to 8 Devices. A System with 32 Display Stations and/or Printers, therefore, would require three additional Device Adapters be installed in a Controller.

5. Display Station (0771) (0772)

The PLUS 70 Display Station with an attached Keyboard enables the user to enter, modify, or delete data and to return the revised data to the data processing system for storage or additional processing. The PLUS 70 Display Station contains a 768 word PROM for control program storage, and a 2K RAM Display Memory. The PROM is expandable to 4K and the Display Memory is expandable to 4K.

Display Size: 1920 characters (24 lines x 80 characters).
480 characters (12 lines x 40 characters).

Power Requirements: 115/220 VAC, 50/60 Hz, 200 watts.

Dimensions: 17.5" high x 16" wide x 21" deep, excluding Keyboard.

Controls: Power On/Off, contrast, brightness, self-test switch, located on lower front panel for easy accessibility.

Character Formation: 7 x 9 dot matrix.

Character Size: .20" high, .08" wide.

CRT: 14" anti-glare screen (white on black), green characters optional.

Cursor: Blinking or non-blinking (switch selectable).

Refresh Rate: 60 Hz Domestic, 50 Hz International

Cabling: RG62/AU single coaxial cable is used from the Display Station to the Controller, 2000 feet maximum allowable lengths; existing 3270 terminal cables are usable.

Connectors: BNC, AMP 225395-2 or equivalent.

Weight: 66 pounds.

Power Cord: Standard 6 feet, 3 wire ground.

6. Keyboards

Five basic types of Keyboards are available for the PLUS 70 System. Included are 66 and 78 key versions. The type of keyboard determines the characters and symbols that may be entered from the Display Station but does not determine which characters can be transmitted from the system for display.

The 78 key keyboard provides added operator-to-program message flexibility with 12 additional keys programmed to fit application program requirements.

Any mix of keyboard types may co-exist on the same controller.

Typewriter Keyboards (0630) 66 Key, (0633) 78 Key.

The typewriter keyboards are the basic typewriter key layout with both upper and lower case codes. This keyboard is available with program function keys PF1 through PF12 (78 key version) or without (66 key version).

Typewriter Keyboard (0634) 78 Key with a 10 Key Numeric Keypad

This keyboard is available with program function keys PF1 through PF12 which are activated by depressing shift, and then the desired PF key. The numeric pad is normally enabled. (Upper and Lower case)

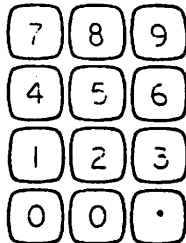

Data Entry Keyboard (0631)

This keyboard has the basic data entry key layout. When characters are entered in a numeric field, the keyboard is upshifted to take advantage of the grouped numeric keys. The data entry keyboard contains 66 keys including five program function keys PF1 through PF5. (Upper case only)

Operator Console Keyboard (0632)

This keyboard provides an IBM 1052 Model 7 type of key layout. It has 78 keys which include program function keys PF1 through PF12. The cancel key replaces the PA2 key on this keyboard. There are no dup code or field mark keys available on this keyboard.

66 key keyboards are 15.5" wide, 3.5" high, and 7" deep, and are connected to the Display unit by a 3 foot cable. 78 key keyboards are 18.5" wide, 3.5" high, and 7" deep with a 3 foot connecting cable.

Keyboard Weight: 7 pounds.

Keyboard layouts and nomenclature may be found on Page 4.

Printers

There are three Printers available for the PLUS 70 System. All models are interchangeable with the IBM 3284/3286/3288 Printers.

- (1) Model 0842: 80 CPS, buffered, may be connected to the Trivex 0712 and 0722 Controller, or to the IBM 3271 or 3272 Controller.

KEYBOARDS FOR TRIVEX PLUS 70 DISPLAY STATIONS

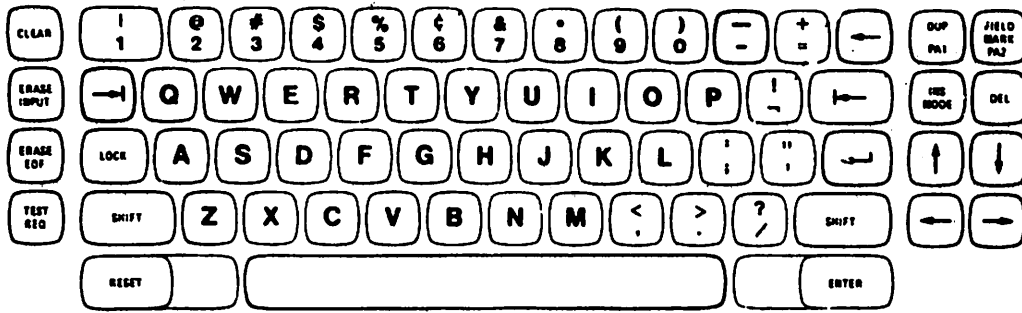

0630-KEYBOARD, TYPEWRITER 66 KEY EBCIDIC

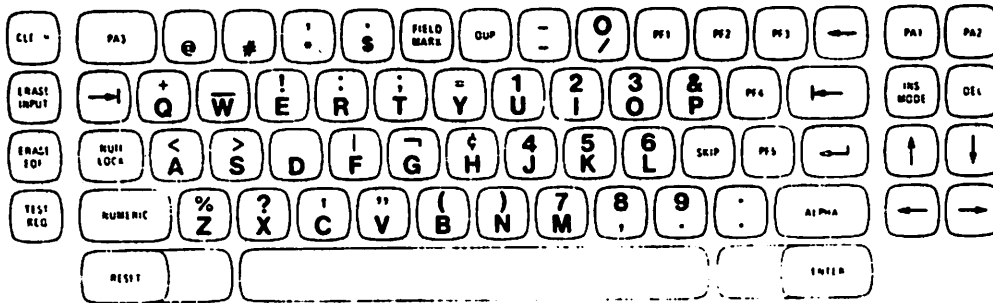

0631-KEYBOARD, DATA ENTRY 66 KEY EBCIDIC

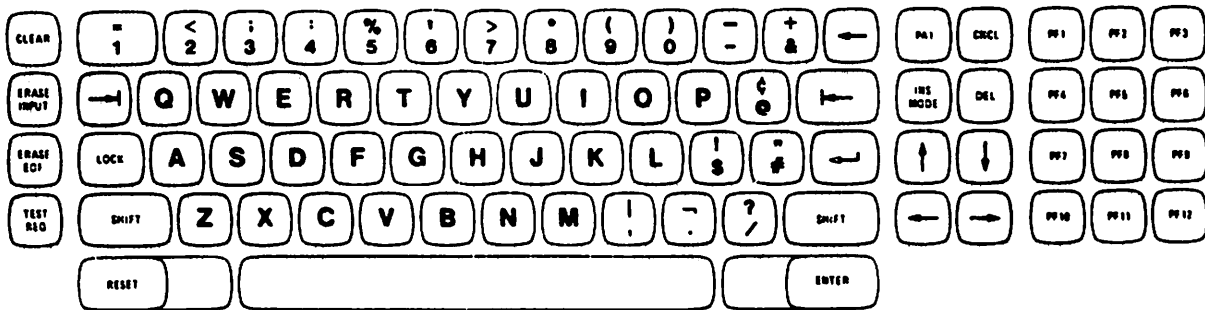

0632-KEYBOARD, OPERATOR CONSOLE 78 KEY EBCIDIC

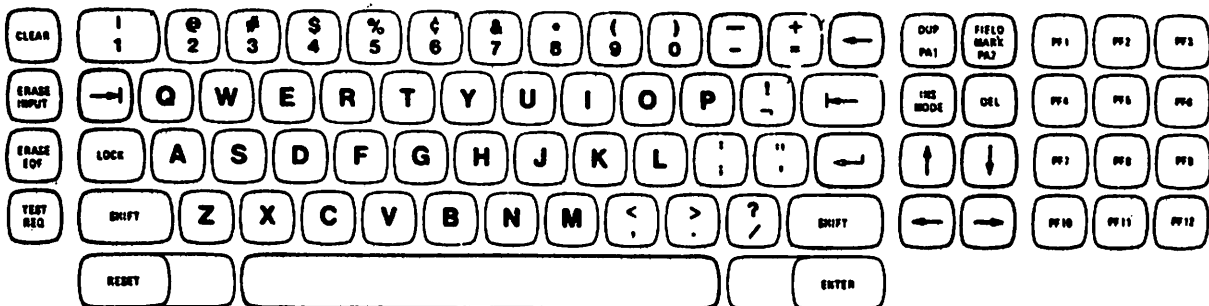

0633-KEYBOARD, TYPEWRITER WITH 12 FUNCTION KEYS, 78 KEY EBCIDIC

(2) Model 0862: 165 CPS, buffered, may be connected to the Trivex 0712 or 0722 Controller, or to the IBM 3271 or 3272 Controller.

NOTE: An 0844 or 0864 version of the above Printers is available whereby the Printer electronics is detached from the Printer and connected by a 20 foot cable. This version is especially useful in environments where space is limited.

(3) Model 0884: 125 LPM, buffered, may be connected to the Trivex 0712 or 0722 Controller, or to the IBM 3271 or 3272 Controller.

Printer Specifications 0842/0862

Print Method: Impact, bidirectional, character by character, one line at a time.

Character Structure: 7 x 9 dot matrix.

Character Set: 64 character code assignments, (96 or 128 optional).

Print Line: 132 characters (maximum).

Buffer Size: 1920 characters.

Dimensions: 28½" wide x 42" wide x 19" deep.

Weight: 160 pounds.

Switch Controls: Power On/Off, select, error reset, forms override, top of form, print test, line feed.

Number of Copies: Original plus four carbons.

Electrical Requirements: 115/230VAC, 50/60 Hz, 600 watts.

Forms Control: Top of form and vertical tab; one inch paper tape of which 2 channels are used.

Cable: Printer to Controller connecting cable, 2000 feet maximum, RG-62/AU single coaxial.

Indicators: Paper out, hardware alarm, system available.

Recommended paper weights:

Single part form - 15 to 20 pound paper.

Multiple part form - Original form 12 to 15 pound paper.

Copies - (up to four) 9 to 12 pound paper.

Carbon - 7 to 7.5 pound paper.

Format: 6 or 8 line per inch spacing.

Paper slew rate: 80 CPS = 44 milliseconds per line.

165 CPS = 25 milliseconds per line.

Audible alarm: 2 second tone to alert the operator to a special condition.

Print line formatting: Printout operations are specified by a write command in remote operation. The print line format can be specified as part of the command in one of three formats which define the print length: 40, 64, or 80 character positions per line. If line length is not formatted, the print line is selected by switches in printer controller for up to 132 characters.

Print line formatting: (continued)

Printing starts after the controller to printer buffer transfer is completed. Printouts can be formatted in the same manner as a display message. Cursor information is ignored by the printer.

Printer Specifications 0884

Print Method: Impact, dot matrix
Character Structure: 5 x 7 dot matrix, 5 x 9 lower case
Character Set: 64 character code assignments, (96 or 128 optional)
Print Line: 132 characters (maximum)
Buffer Size: 1920 characters
Dimensions: 23" wide x 8.5" high x 22" deep
Weight: 85 pounds
Number of Copies: Original plus four carbons
Electrical Requirements: 115/230VAC, 50/60 Hz, 500 watts
Forms Control: Electronic top of form, Switch Selectable for 3" to 14" forms.
Cable: RG 62/AU single coaxial-to 2000 feet.
Format: 6 or 8 line per inch spacing, switch selectable.
Detached Interface Electronics: Can be placed up to 20 feet from the printer.
Dimensions: 15" wide x 22" high x 20" deep
Weight: 95 pounds

8. Stand Alone Display Station (0752)

Interchangeable with the IBM 3275-2 Display Station. A single Remote Display Station operating in half duplex multipoint mode on half duplex or full duplex facilities at transmission speeds switch selectable from 300 to 19,200 BPS.

The 0752 displays 24 lines of 80 characters (1920 characters). One optional unbuffered printer may be attached to each 0752 Display Station.

Three models of unbuffered printers are available:

0843: 80 CPS
0863: 165 CPS
0883: 125 LPM

The following options are available for the (0752).

1. The three aforementioned printers
2. Lite pen
3. OCR Wand
4. Any of the five available keyboards.

Keyboard activated Print Request

This feature incorporates automatic print format selection. The screen contents are printed in the following formats by depressing RESET and: numeric key 1 for 40 characters/line, numeric key 2 for 64 character/line, numeric key 3 for 80 character/line, numeric key 4 for unformatted print.

9. TRIVEX PLUS 70 MINI CLUSTER DISPLAY SYSTEM (0712M)

The Trivex Plus 70 Mini Cluster System is designed for remote installations with 8 or less display stations or printers, operating via modems in BSC data link mode.

The basic system consists of an 0712M Master Display Station-Controller, which operates exactly the same as the IBM 3271-2 Controller or the Trivex 0712 Remote Controller.

Seven additional devices may be connected to the controller, such as:

0842	80 CPS Printer
0862	165 CPS Printer
0884	125 LPM Printer
0772M	DISPLAY STATION (1920 characters)

The system operates in half duplex mode at switch selectable speeds to 19,200 BPS.

A self diagnostic program is resident within the controller microprogram for immediate fault isolation, and also has the operator self test feature.

The basic controller supports up to four devices. An additional device adapter is required for devices 5-8.

Devices are connected to the controller with single coaxial cable and may be installed up to 2000 feet from the controller.

The optional display to print feature is also available.

Configuration Restrictions

The master display station will not support the OCR wand.
The master display station will support the optional lite pen, key lock, 25th line prompting, and all keyboards.

There are no option limitations on the seven devices that may be attached to the master display station/controller.

CONFIGURATIONS

Local PLUS 70 System Configuration

The PLUS 70 Local Controller connects to either a 360 or 370 system through a block multiplexer, byte multiplexer, or selector channel via one of the eight control unit positions on the channel interface:

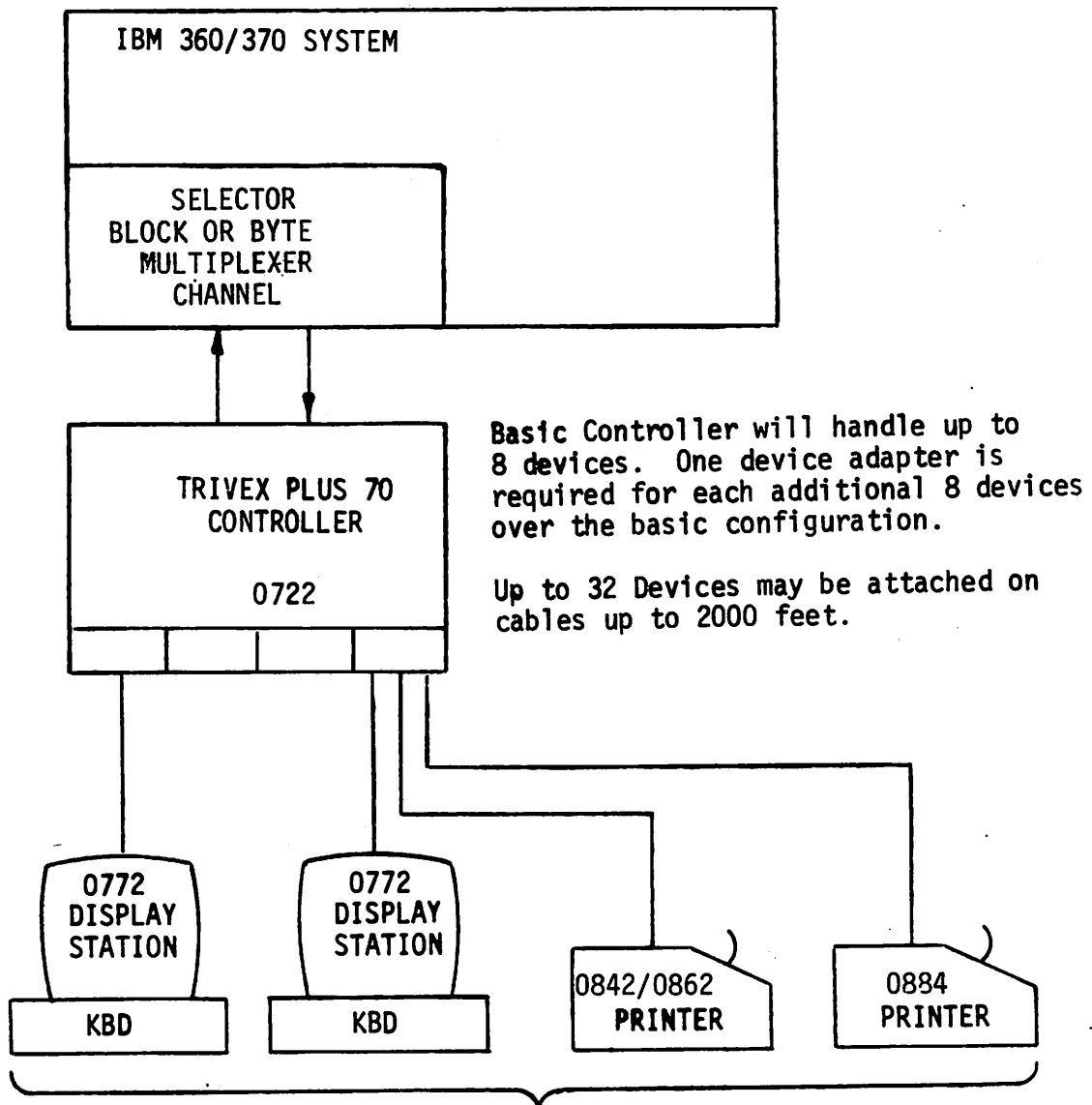

User may configure 32 of any combination of the following devices:

- 0771 Display Station
- 0772 Display Station
- 0842 Printers
- 0862 Printers
- 0884 Printers

Remote PLUS 70 System Configuration

In a remote configuration a transmission control unit is cabled directly to the 360/370 system multiplexer channel. The TCU relays data and control information in (BSC) mode over modems to the Remote Controller, or Stand Alone Display Station.

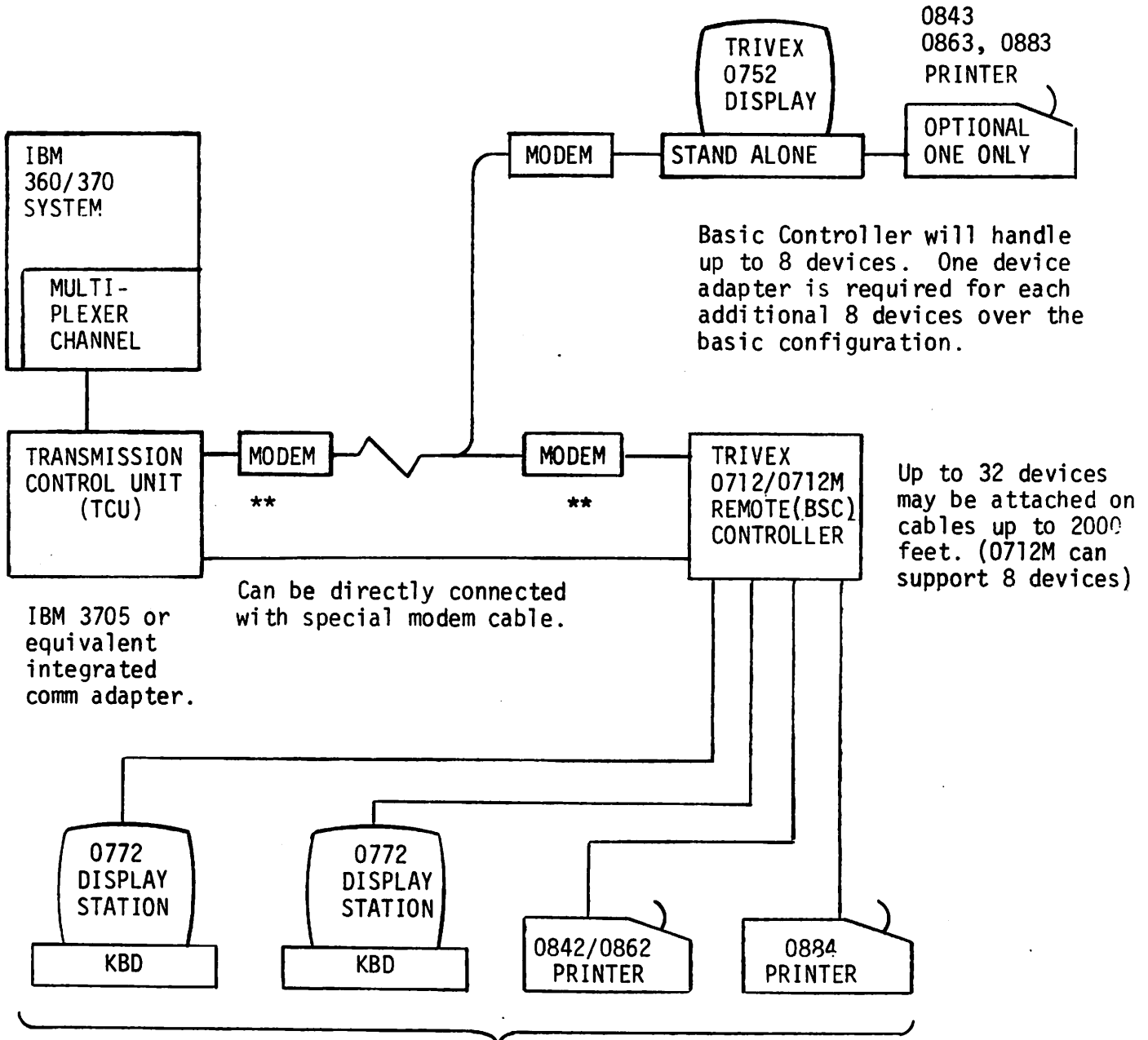

User may configure 32 of any combination of the following devices:

- 0771 Display Station
- 0772 Display Station
- 0842 Printers
- 0862 Printers
- 0884 Printers

** Modems 110 to 9600 BPS

FEATURES

PLUS 70 Standard Features

1. Microprocessor control in all system components.
2. Extensive diagnostic capability in all system components, which are explained in detail in the System Test Features section.

Display Stations

1. Switch Selectable blink or non-blink cursor.
2. Dots in each character position in variable fields. The dots are replaced by characters entered by the operator. (Switch selectable)
3. Switch selectable audible alarm to alert the operator upon illegal entry.
4. Tab to Colon: switch selectable.
5. Switch selectable self-test feature.

Controllers

1. Status Report - Information on all devices in the system is available by depressing the test request key on any display station. This information is displayed on the requesting station and provides status information on the controller (Local or Remote), and all devices connected to the controller. In a remote system the status report may be requested by the computer center via a special read command and can be displayed or printed for analysis.
2. Eight devices are supported by each Device Adapter. (0712 and 0722)
3. Four devices are supported by each Device Adapter on the 0712M mini cluster.

Printers

1. Form feed control feature in the Printers allows forms to advance under program control. The paper tape loop is programmed for the forms length. Upon detection of a FF character (hex 0C) in the data stream, the Printer advances to the predetermined print line on the next form.
2. Vertical tab control feature in the Printers allows forms to advance under program control to a predetermined print line. The paper tape loop is programmed for the required line spacing. Upon detection of a VT character (hex 0B) in the data stream, the Printer advances to the next predetermined print line on the form.
3. Underscored print on error. Parity errors are printed as underscores.
4. Choice of platen lengths. (One to 132 characters).

5. Switch selectable line spacing. Single or double lines.
6. Expanded character printing providing a BOLDFACE EFFECT (switch selectable). Upon detection of an SO command in the data stream (HEX 0E), the line to be printed will be expanded.

PLUS 70 Optional Features

Display Stations

- (032) Lower case character set with descenders
- (033) Prompting line:(0772 only),line and character position counts are displayed on a 25th line, above line one in the display area. The following prompting messages are also displayed on the 25th line:
 1. Print pending
 2. Numeric field error
 3. Protect error
 4. Attention pending
 5. Printer not ready
 6. Insert error
- (034) Security lock: Allows the operator to use a key to disable the PLUS 70 Display Station when it is left unattended. The Display Station is enabled with the key inserted and turned to the ON position.
- (035) Lite pen: The lite pen is a light sensitive pen which detects the light emitted from characters displayed on the screen. The operator may select displayed items from a list or table and cause those selected to be identified to the application program. The pen is operated by pressing the tip against the screen on fields programmed for lite pen operations.
- (036) Reader ID Card: Accepts a small magnetic card encoded with a unique ID number for accounting or security purposes.
- (037) OCR Wand: A hand held device for reading records directly from the source in OCR-A font. Eliminates manual keying with greater speed and increased accuracy. The input data is fed directly to the PLUS 70 Display Station microprocessor through an RS-232C interface.
- (038) Transaction Statistics:

Three values are accumulated for each display attached to the Controller. These values are:

 1. Number of transactions regardless of response time.
 2. Number of transactions exceeding threshold.
 3. Maximum response time since last reset.

Transaction is defined as a positive response to a poll caused by an attention key being depressed at the display station.

Response time is defined as the time between the recognition of an attention key by the Controller, and the return of a write command, with keyboard unlock in the WCC, by the system.

Threshold is defined as a number of seconds, preset by the system. The value is represented as a 6 bit binary number plus 1. This allows a range of from 1 to 64 seconds. The threshold value is set to 64 seconds at power up or reset. The threshold is set by the 6LSBs of the character following the WCC of a status write command.

- (021) Display Print: This option allows the user to assign a Printer to a Display Station, and dump the contents of a Display Station screen to the assigned Printer for printout by using a Program Function key.

Controllers

- (020) Device Adapter: Provides the facilities necessary to service up to eight devices.
- (020M) Device Adapter: Provides the facilities necessary to service up to four devices on the 0712M mini cluster.

Printers

- (045) Forms stand for Trivex series 840 and 860 printers. Allows stacking of printed forms.
- (046) Trivex printer ribbons.
- (048) Dust cover/Tear Bar for Trivex 840 and 860 series printers.
- (049) Forms stand for Trivex Model 0884 line printers.
- (051) Printer table: Used for printers with detached interface electronics.
- (053) Format Control Memory for 840 and 860 series printers. Allows the user up to 8 different forms types. Replaces the paper tape forms control feature.

PLUS 70 SYSTEM OPERATION

Display Operation

Information in the 0772 Display Memory is presented to the operator on a cathode ray tube (CRT). The display is refreshed continuously to maintain a constant image on the screen. There is a fixed relationship between each Display Memory location and the related character position on the screen. Memory address locations are referenced from 0 in the upper left hand portion of the screen to 1919 in the lower right hand portion. By using these address locations a program can load a Display Station Memory with many combinations of control and data characters to present to the operator. 93 codes may be transferred and from the system processor and stored in the Display Station Memory, including upper and lower case alphameric characters, special characters, two printer control characters (EM and NL), and two lite pen control characters (? and >). Additionally they include attribute characters which define the characteristics or attributes of the data that follow them. Each attribute character and all of the data following it up to the next attribute character is called a field.

There are two basic methods a program may communicate with the display operator: unformatted, where the operator uses the screen in a free-form manner, and formatted, where the display is organized and arranged by the application program.

<input type="checkbox"/> NAME:	<input type="checkbox"/> JOHN SMITH	} Formatted Display
<input type="checkbox"/> JOB TITLE:	<input type="checkbox"/> BUYER	
<input type="checkbox"/> PHONE #:	<input type="checkbox"/> 546-7781	

Attribute characters also define the following field characteristics for all character locations contained in that field:

Protected (from modification by a display operator) or unprotected (available for the operator to modify or enter data). The unprotected definition classifies a field as an input field.

Alpha or Numeric.

Character display (non-display, display, intensified display).

Detectable or non-detectable (by use of lite pen).

Tab stop positions (first character occupies one of the 1920 character following a colon in an unprotected field). (optional)

Each attribute character occupies one of the 1920 character locations in the buffer, but it cannot be displayed or printed. During a display or printout, it appears as a space.

KEYBOARD OPERATIONS

Cursor Positioning Controls

Up (↑), Down (↓), Left (←), Right (→) Keys
Backspace (↵) Key
Tab (→) or Skip and Backtab (↵) Keys
New Line (↵) Key
Home (↵) Reset and Backtab

Editing Controls

INS mode key. Allows characters to be inserted into a field, shifting right all characters following the point of insertion.

DEL key. Allows characters to be deleted, shifting left all characters on the same line and following the point of deletion.

Program Function Keys

Program function (PF) keys allow input data on the screen to be sent to the program with a code that identifies the program function key that was pressed. Program access keys (PA) allow a code to be sent to the program to identify the key being depressed, but no input data is sent from the screen to the program.

Numeric Lock Feature

Alerts the operator to certain keying errors. With a data entry keyboard, when the cursor is positioned within a numeric input field the Display Station automatically upshifts the keyboard. With the numeric lock feature, the keyboard is locked if any key other than the numerals 0 through 9, minus (-), period (.), or duplicate (DUP) is pressed.

Shift Keys

The typewriter and operator console keyboards are provided with the standard typewriter shift keys: SHIFT and LOCK. These keys operate exactly like typewriter keys.

Data entry keyboards are provided with the alpha (alphameric) and numeric shift keys. The alpha shift key is used to override a numeric (input) field definition and the numeric lock feature to purposely input alphameric data into a numeric field.

The numeric shift key overrides the numeric field definition and numeric lock condition to permit upshift character entry for other characters.

Duplicate (DUP) Key

This key allows a unique code, which is displayed as an asterisk (*), to be sent to the program, while the cursor is advanced automatically to the next input field. The DUP code is interpreted by the program to mean duplicate this field from the previous record.

Erasing Controls

The clear, erase EOF, and erase input keys provide erasing functions by setting to null codes any character positions on the display image that are affected by the key operations.

Clear Key: Used if the operator is to erase the entire display image and the image format. The clear key also causes an interrupt in the data system program.

Erase EOF: Used when the operator inputs data into part of the field and wants the rest of the field erased.

Erase Input: Used to erase all input fields on the Display.

PRINTER OPERATION

Buffered 80 CPS, 165 CPS, 125 LPM

Trivex provides three types of Printers for the PLUS 70 System, 80 CPS, 165 CPS and 125 LPM. All have a 1920 character buffer, a unique device address, and may be attached to an 0712 and 0722 Controller, The Printer operates in the same manner as a Display Station.

End of Message and New Line

NL - New Lines, EM - End of Message, FF - Form Feed. NL, EM, and FF commands are transferred to the Printer as part of the data stream from the application program. NL and EM commands are executed only when encountered in a print field that does not have a line-length format specified. Form Feed commands are executed during all printouts.

NL and EM commands are not executed when located in a non-display/non-print field; instead, they are treated as alphameric characters and printed as spaces.

Forms Control

The Trivex Model 840/860 Printers utilize a paper tape reader, of which 2 channels are used. Channel 5 is used for vertical tabbing and Channel 7 is used for Top of Form. A hole is punched in Channel 5 at each interval corresponding to the number of print lines to be tabbed. A hole is punched in Channel 7 once for each interval, corresponding to the total number of print lines from one index stop to the next.

FF Characters must be placed in one of the following program locations:

1. The first character location of a printer message.
2. After a valid NL order.
3. After the last printable character position of any line (e.g., in character position 41 with a line length format of 40 characters for the line specified, or in character position 133 without a line length format specified.)

The Model 884 printer utilizes an electronic forms control which is set by an operator switch to the forms length desired.

Error Conditions

1. Not ready. Defined as the Printer being out of paper, or mechanically disabled. A printer not ready at the start of a printout, or becoming not ready during a printout, will terminate the print operation. Error status is sent to the channel once when the condition occurs during a printout, and again each time a printout is initiated.
2. Parity Error. If a character with incorrect parity is detected, an underscore is printed in place of the character. Printout continues until all printable characters have been printed. The Printer then prints an X to indicate the error detection.
3. Command Chaining. In local operations, if any command is chained to a command that initiates a print operations, an error condition occurs. At this time no printout is performed, the command is aborted, and the system channel is notified of the error. In remote operations, if command chaining is attempted, error status is sent to the system channel but the printout is completed.

Local Display Print (0772 Display Station)

The Local Display Print Option allows the user to obtain hard copy output from a Printer locally, without intervention of the host system.

Two modes of local display printout are available with this option:

1. Priority Print. The first available Printer starting from the Display Station address will print the entire contents of the Display Station buffer. When the operator depresses the RESET and PF3 keys.
2. Assigned Print. The 2 digit hex address of the Printer to be assigned is entered on the Display Station and assigned by activating the RESET and PF2 keys. The buffer contents of the Display Station can then be printed on the assigned Printer by using the RESET and PF1 keys.

PLUS 70 SYSTEM TEST FEATURES

Remote Status Report

The Trivex Remote Controller microprogram contains a Maintenance Aid Program (MAP).

Included in MAP is a Status Display Program which will upon request display the Remote Status Report.

Status Information is displayed on the requesting station, and gives status on all devices and the Controller.

The status report is displayed by activating the status switch on the Controller and depressing the Test Request Key on the requesting Display Station.

The report is easily read and interpreted and may also be requested by the central computer site by using a special read command. The counters in the Controller can be reset to zero, enabling the user to plot periodic readings to determine trends and predict communication problems, possibly preventing some of these from occurring.

Some examples of Status Report Information are:

1. Controller - NAKS sent and received from the host system
Control Unit Poll Address
Overrun Error (internal)
Last Device Status
Last Command received
2. Device - Device Transmit Check
Retry Count
Device is a Printer
Device is Busy
Device Timeout on Poll or Command
Device responded with Parity Error
Device detected Device Check
Device has Information Pending

A complete description of the Remote Status Report is contained in the Trivex MAP Program description.

Local Status Report

The Trivex Local Controller microprogram also contains a Maintenance Aid Program.

Included is a Status Display Program which upon request displays the Local Status Report.

Status information on all devices and the controller is displayed on the requesting station.

The Local Status Report is displayed by activating the status switch on the controller and depressing the Test Request key on the requesting Display Station.

The Local Status Report contains numerous bytes of sense information on controller - channel communications, and also device status information such as addressing assignments, sense line data, and device error counts.

A complete description of the Local Status Report is contained in Appendix 3.

PLUS 70 Display Station Test Features

Due to the large number of Display Stations that may be included in a system, Trivex has included a number of on line test features for immediate customer identification of a Display Station error.

In addition to the standard on line indicators, system available, insert mode, and input inhibit, which are related to terminal - controller communications, the Trivex PLUS 70 Display Station has five additional indicators for instant display of terminal status. The Display Station has an internal switch which controls the display of the five additional indicators so they may be displayed or blanked.

The additional indicators are:

1. OK Indicator - This indicator blinks at a fixed rate to indicate correct operation of the Display Station Processor. A read/poll command will cause this indicator to remain in one state until I/O is terminated.
2. Information Pending - Indicator set by any program function (PF or PA) which causes a computer interrupt in local operation, and a response in remote operations.
3. Spurious Acknowledgements - Indicator set by a Display to Controller transmission error, an acknowledgement being a normal response to an information pending condition.
4. Device Check - Indicator is set by a parity error on received data from the Controller.

The OK Indicator will blink at a fixed rate and the other four will remain off during normal operation. Any variation from the normal indications allows the user to identify a defective terminal and take it off line without interrupting system operation.

The Display Station also has extensive off line test features controlled by the use of the keyboard to access a self contained test program in the Display Station. This feature plus modular design allows the customer engineer to get a Display Station back on line in a matter of minutes.

The Off Line tests expand the fault isolation capability to include Keyboard, keyboard interface, buffer memory, and display.

PLUS 70 Remote Controller Test Features

The Trivex Remote Controller microprogram contains a self test diagnostic program. This self-test program is constantly testing the controller while off line. If a failure occurs, the indicators show the test which failed.

The controller interface to the modem may also be tested by disconnecting the modem cable, installing a jumper plus, enabling the loopback switch in the controller, and checking the indicators on the controller. If the indicators are on continuously, the controller interface is defective.

On remote systems, an external loopback test can also be used to isolate a defective modem. The loopback switches in the controller and modem are activated and the indicators on the controller indicate a modem failure.

The self test features of the Trivex PLUS 70 controllers mean immediate fault isolation without prolonged test time and interruption of system operation.

PLUS 70 Printer Test Features

The Trivex Printers have extensive fault isolation test features.

The Printers have a hardware alarm indicator on the switch panel which, when on, indicate an error in the Printer optics or a paper malfunction.

A pushbutton print test switch is also located on the switch panel. When the Printer is on line, depressing this switch will print the status report. When the printer is off line, depressing this switch will print a 132 character line of the character H to enable the operator to identify a malfunction immediately.

The Printers may be operated in either of two switch selectable off line maintenance modes.

Mode One - Allows printing of any data in the Printer Controller, buffer, such as remaining customer data.

In this mode, a standard PLUS 70 keyboard can be plugged directly into the Printer Controller to enter keyboard codes for accessing specific tests contained in the resident microprogram. These tests allow the customer engineer to test the Printer controller completely, and isolate the problem area.

Mode Two - In this mode, a series of alphanumeric test patterns are printed to test the buffer memory and print logic.

The two off line maintenance modes assure 100% test capability of all Printer components.

TRIVEX PLUS 70
REMOTE SYSTEM MAINTENANCE AID PROGRAM (MAP)
PROGRAM DESCRIPTION

1. GENERAL

The Trivex Plus 70 Remote Maintenance Aid Program provides the capability for transmission of a "Diagnostic Message" to the central computer site regarding the operation and status of the Plus 70 Display System.

Information concerning the Controller, Display Stations, Printers, and communications link is available to system operations personnel for immediate fault isolation.

2. OPERATIONAL DESCRIPTION

The Trivex model 712 Remote Controller is designed using a factory installed microprogram package to achieve IBM 3271 compatibility.

The microprogram contains a maintenance aid program (MAP), which provides both on line and off line maintenance aids.

MAP includes a status display program which can be initiated from any Display Station by depressing the test request key. Status information is displayed on the requesting terminal regarding the Controller and all devices connected to the controller.

The status display may also be requested from the computer center by using remote status read and write commands to retrieve and initialize data contained in the remote status display.

Especially useful are the NAKS sent and NAKS received counts which can be used to isolate communications problems.

Also included in MAP are a group of diagnostic subroutines that must be successfully completed prior to entering the operational Remote Controller program.

- SUBROUTINES * Timer Test
* Buffer Test
* Cursor EOP Test
* BSC Internal Loopback
* BSC External Loopback
(off line only)

The front panel indicators on the controller are used to determine the nature of any errors encountered. (Appendix 1)

3. PROGRAMMING CONSIDERATIONS

1. Contents of status display information are contained in Appendix 2.
2. Device addressing for remote status read and write commands may be either:
 - a. HEX 7F
 - b. Any on line and error free device. The use of device address 7F selects the controller only, thus eliminating any device involvement in the command execution.
3. Other commands should not be chained to status read/write commands. Exception: A status write may be chained from a status read.

4. STATUS READ OPERATION

1. The command code for a status read is HEX 7E
2. The command data stream is:
-STX ESC 7E ETX-
3. The WCC specifies which counts are to be reset.
 - a. Bit 2 resets NAKS sent.
 - b. Bit 3 resets NAKS received.
 - c. Bit 4 resets all device retry counts.Note: A WCC* of HEX F8 will reset all counts.

APPENDIX I

FRONT PANEL INDICATORS

0 SYSTEM READY	0 SYNC SEARCH	0 SELECTED	0 CTS WAIT	0 TRANSMIT	0 STATUS	0 POWER ON
INTERNAL DIAGNOSTIC USAGE						
DATA SET READY AND CARRIER DETECT			X	X	X	TIMER FAILURE
			X		X	BUFFER FAILURE
			X	X	X	CURSOR/EOP FAILURE
		X			X	INTERNAL LOOP BACK FAILURE
					X	*EXTERNAL LOOP BACK FAILURE

* OFF LINE ONLY

APPENDIX II

REMOTE SYSTEM STATUS DISPLAY

Display screen activated by test request key with status switch on and in local position.

1A	2A	1B	1C	1D	1E	2B	2C	2D	1F	2E	2F	2G	2H	3A	3B	1G
01	00	1F	1	18	00	04	1000	10	11	7F	01	42	40	00	00	6271
00	01	42	40	35	30	00	00			01	01	42	40	00	00	08 00
02	02	00	00	00	00	80	FF			03	03	00	00	00	00	80 FF
04	04	00	00	00	00	80	FF			05	05	00	00	00	00	80 FF
06	06	00	00	00	00	80	FF			07	07	00	00	00	00	80 FF
08	08	00	00	00	00	80	FF			09	09	00	00	00	00	80 FF
0A	0A	00	00	00	00	80	FF			0B	0B	00	00	00	00	80 FF
0C	0C	00	00	00	00	80	FF			0D	0D	00	00	00	00	80 FF
0E	0E	00	00	00	00	80	FF			0F	0F	00	00	00	00	80 FF
10	10	00	00	00	00	80	FF			11	11	00	00	00	00	80 FF
12	12	00	00	00	00	80	FF			13	13	00	00	00	00	80 FF
14	14	00	00	00	00	80	FF			15	15	00	00	00	00	80 FF
16	16	00	00	00	00	80	FF			17	17	00	00	00	00	80 FF
18	18	00	00	00	00	80	FF			19	19	00	00	00	00	80 FF
1A	1A	00	00	00	00	80	FF			1B	1B	00	00	00	00	80 FF
1C	1C	00	00	00	00	80	FF			1D	1D	00	00	00	00	80 FF
1E	1E	00	00	00	00	80	FF			1F	1F	00	00	00	00	80 FF
2I	2J	2K	2L	2M	2N	2O	3C									3C

GROUP 1 - Configuration Information

- 1A CUPA: Control Unit Poll Address
- 1B HDVCA: Highest Device Address
- 1C MCL: 1=Modem Clocking Selected
- 1D BAUD: Baud Rate/100 in hex
- 1E CTSD: Clear to Send Delay (in milliseconds)
- 1F DIAG: Diagnostic Switch (Status Display)=1 (Local)
- 1F ON LINE: On Line Switch
- 1G VERS: Version of Operational Program

GROUP 2- Maintenance/Diagnostic Information

- 2A DVCA: Device Address of requesting Terminal
- 2B CUSNS: Control Unit Sense Register
- 2C LINE: Carrier, Data Set Ready, CTS/RTS, Received Character Ready
- 2D XMIT: Transmit register Empty=1, Overrun Error=0
- 2E LCR: Last Command Received
- 2F LDS: Last Device Status, Device Status, Device Address for SS Bytes
- 2G SS0: Last Status Byte 0, Device Address for SS Bytes
- 2H SS1: Last Status Byte 1
- 2I DA: Device Address
- 2J PA: Printer Assignment
- 2K SS0: Status Byte 0
- 2L SS1: Status Byte 1
- 2M LCR: Last Command Received
- 2N DA HOLD: DAC Received from Device
- 2O DAC STATUS: DAC Detected Information

GROUP 3 - Error Accumulation Information

- 3A NKS: Counter of NAKS sent to Remote Channel (TCU)
- 3B NKR: Counter of NAKS received from Remote Channel
- 3C RETRY: Controller/Device Communication Link (Error Counter)

GROUP 1 CONFIGURATION INFORMATION

1A. CUPA: Control Unit Poll Address

The address the controller will respond to when either polled or selected. The address is displayed as "00" through "IF".

1B. HDVCA: Highest Device Address

The device limit setting on the control unit. The control unit will not access any device that is attached to an address higher than the limit setting.

1C. MCL: Modem or Internal Clocking

Modem Clocking Selected-the setting used if the data set is supplying the clocks for the control unit.

Internal clocking selected is used if the data set does not supply clocks or the control unit is attached to the TCU directly through a special cable.

1D. BAUD: Internal Clock Rate or Modem Clock Rate

Off line the Baud Rate is the internal clock rate unless external loop test is being run through the data set.

On line the Baud Rate is the data set clock rate.

Note: The data set clock rate becomes valid after the first transmission. External loop test through the data set will also give the data set clock rate.

1E. CTSD: Clear to Send Delay

Off line the clear to send delay will be "0" unless external loop back is being run through a modem.

On line the clear to send delay becomes valid after any transfer of "SS" or Text.

GROUP 2 MAINTENANCE/DIAGNOSTIC INFORMATION

2A. DVCA: Device Address of Requesting Terminal

The address of the station displaying the status.

2B. CUSNS: Control Unit Sense Register

Indicates the position of the switch options on the remote interface.

2C. LINE: 1 = Yes 0 = No

Carrier - Signal detect is present from modem (carrier).

Data Set Ready - Line must be high from the modem.

Clear to Send/Request to Send - Must be 0.

Received Character Ready - Program has received a character from the line.

2D. XMIT:

Transmit Register Empty - Must be a "1" which means that controller is not transmitting at the time the status display is generated.

Overrun Error - Must be a "0". A "1" means that the remote interface received a character before the program accepted the previous one.

2E. LCR: Last Command Received (Controller)

Indicates the very last command that the remote controller received from the CPU.

2F. LDS: Last Device Status

Indicates the address of the device which had the last status information for the CPU.

2G. SS0: Last Status BYTE 0

Indicates the last status BYTE 0 that the remote controller sent to the CPU.

2H. SS1: Last Status BYTE 1

Indicates the last status BYTE 1 that the remote controller sent to the CPU.

2I. DA: Device Address

The device adapter address for each terminal.

2J. PA: Printer Assignment

The printer address of an assigned printer (display print).

2K. SS0: Status BYTE 0

The last status BYTE 0 that this device sent to the CPU.

2L. SS1: Status BYTE 1

The last status BYTE 1 that this device sent to the CPU.

2M. LCR: Last Command Received (Device)

The last command to be directed to this device. A poll command will only be displayed if a text block is sent in response to the poll.

Note: A status message is not considered a text block.

2N. DA HOLD: DAC Received from Device

Data that the controller receives from the device.

2O. DAC STATUS: DAC Detected Information.

Information about the condition of the device.

GROUP 3 ERROR ACCUMULATION INFORMATION

3A. NKS: Counter of NAKS Sent to CPU

The current count of NAKS that the remote controller sends to the system. Resetting the controller or sending the proper "WCC" in a status write will clear this count to Zero.

3B. NKR: Counter of NAKS Sent from CPU

The current count of NAKS that the system has sent to the remote controller. Cleared same as NKS.

3C. RETRY: Controller/Device Communication Link

This is the number of errors that the controller has detected during I/O with a device through the Coaxial I/O circuit card. The Retry count is on a per device basis. Resetting the controller or sending the proper "WCC" in a status write or setting loop switch "ON" while on line, will clear all device retry counts.

LOCAL SYSTEM STATUS DISPLAY

<u>1A</u> 40	<u>1B</u> 40	<u>1C</u> 47	<u>1D</u> 111	<u>1E</u> 7F	<u>1F</u> 0000	<u>1G</u> 000	<u>1H</u> 03	<u>1I</u> 02	<u>1J</u> 41	<u>1K</u> 05	<u>1L</u> 0	<u>1M</u> 46	<u>1N</u> 40	<u>1P</u> 7188			
40	40	03	60	00	02	30	00	00	41	41	08	E8	00	05	00	08	00
42	42	00	00	40	04	00	80	FF	43	43	03	60	00	02	00	00	00
44	44	00	00	40	04	00	80	FF	45	45	00	00	40	04	00	80	FF
46	46	00	00	40	04	00	80	FF	47	47	03	60	00	02	00	00	00
48	48	00	00	00	00	00	00	00	49	49	00	00	00	00	00	00	00
4A	4A	00	00	00	00	00	00	00	4B	4B	00	00	00	00	00	00	00
4C	4C	00	00	00	00	00	00	00	4D	4D	00	00	00	00	00	00	00
4E	4E	00	00	00	00	00	00	00	4F	4F	00	00	00	00	00	00	00
50	50	00	00	00	00	00	00	00	51	51	00	00	00	00	00	00	00
52	52	00	00	00	00	00	00	00	53	53	00	00	00	00	00	00	00
54	54	00	00	00	00	00	00	00	55	55	00	00	00	00	00	00	00
56	56	00	00	00	00	00	00	00	57	57	00	00	00	00	00	00	00
58	58	00	00	00	00	00	00	00	59	59	00	00	00	00	00	00	00
5A	5A	00	00	00	00	00	00	00	5B	5B	00	00	00	00	00	00	00
5C	5C	00	00	00	00	00	00	00	5D	5D	00	00	00	00	00	00	00
5E	5E	00	00	00	00	00	00	00	5F	5F	00	00	00	00	00	00	00
<u>2A</u>	<u>2B</u>	<u>2C</u>	<u>2D</u>	<u>2E</u>	<u>2F</u>	<u>2G</u>	<u>2H</u>	<u>2I</u>									

I-CONTROLLER LINE

- 1A - BASE ADDRESS
- 1B - REQUESTING DEVICE ADDRESS
- 1C - HIGHEST DEVICE ADDRESS (LIMIT)
- 1D - LDE - LOGIC DRIVER ENABLE
 - ONLSW - ON-LINE SWITCH
 - DIAGSW - STATUS SWITCH
- 1E - CUSNS - CONTROL UNIT SENSE SWITCHES
- 1F - SUP0 - SUPPRESS OUT
 - SELT - SELECT OUT TRAPPED
 - ADRO - ADDRESS OUT AND VALID ADDRESS
 - CMDO - COMMAND OUT
- 1G - SVCO - SERVICE OUT
 - CUEFLG - CONTROL UNIT END REQUIRED
 - IFDC - INTERFACE DISCONNECT
- 1H - BUSOUT
- 1I - STAT (IN TAGS)
- 1J - CSDA - CHANNEL SELECTED DVC ADR.
- 1K - LCR - LAST COMMAND RECEIVED
- 1L - SV - SENSE VALID
- 1M - SNSDA - DEVICE ADDRESS WITH SENSE
- 1N - SNSBYTE - SENSE BYTE
- 1P - VERSION

II - DEVICE STATUS INFORMATION

- 2A - DEVICE ADDRESS
- 2B - PRINTER ASSIGNMENT
- 2C - LAST WCC
- 2D - LAST AID CODE SENT
- 2E - LAST SENSE
- 2F - LAST COMMAND RECEIVED
- 2G - DAHOLD
- 2H - DACSTAT
- 2I - RETRY COUNT

STATUS DISPLAY DESCRIPTION

I. Controller Line

1A - BASE ADDRESS

This is the address of the lowest device on the control unit. The first digit is the control unit channel address. The second digit is the device address. The switch settings for the base address will be found Table 1L.

1B - REQUESTING DVC ADDRESS

This is the address of the device that requested the status display.

1C - HIGHEST DEVICE ADDRESS (Limit)

This is the address of the last device that will be serviced by the control unit. The switch settings for the limit will be found Table 2L.

1D - LOCAL INTERFACE SIGNALS

LDE - When this signal is a 1, the control unit is able to communicate with the channel.

ONLSW - When interface is in the on-line position.

DIAGSW - When interface is "on" enabling the status display

1E - CUSNS - CONTROL UNIT SENSE REGISTER

local interface. Table 3L lists the options and there respective hex value.

1F - OUT TAGS

A 1 means the tag was high from the CPU at the time the status display was requested.

1G - CONTROLLER STAT

CUEFLG - When a 1 the controller was busy and will be available after posting control unit end status

IFDC - When a 1 the controller is disconnected from the channel or off-line. LDE should be a 0 when this signal is a 1.

STATUS DISPLAY DESCRIPTION

1H - BUS OUT

This is the value that was on the bus at the time the status display was requested.

1I - STAT (in

A 1 means the controller has raised the tag to the channel. Table 4L lists the tags and their hex value.

1J - CSDA - CHANNEL SELECTED DEVICE ADDRESS

This is the last address to complete a command with the CPU.

1K - LCR - LAST COMMAND RECEIVED

This is the last command executed by the controller. Table 5L lists the commands that will be displayed.

1L - SV - SENSE VALID

A 1 means the sense BYTE in 1N is still pending in the controller for the device in 1M

1M - SNSDA - DEVICE ADDRESS WITH SENSE

This is the address for which the sense in 1N was posted.

1N - SNSBYTE- SENSE BYTE

This is the sense that is pending or was last sent to the CPU depending on the state of sense valid. Table 6L lists the Hex value of the sense bits.

1P - VERSION

This is the date code of the program installed in the controller.

II. DEVICE STATUS INFORMATION

2A - DEVICE ADDRESS

This is the channel address of the device.

2B - PRINTER ASSIGNMENT

This is the address of the printer. This device will print too if the local display print option is present.

STATUS DISPLAY DESCRIPTION

2C - LAST WCC

This is the last WCC that was sent to this device. Table 7L lists the bit structure for the WCC.

2D - LAST AID CODE SENT

This is the aid code that was last sent to the CPU for this device. Table 8L lists the possible codes. A printer will only have an E8 or 00 displayed.

2E - LAST SENSE

This is the last sense data sent to the CPU for this device. A sense command must be issued by the CPU to receive the sense information and update this field. Table 6L lists the Hex value for the sense bits.

2F - LAST COMMAND RECEIVED

This is the last command directed at this device. The command codes are listed on Table 5L.

2G - DAHOLD - DEVICE ADAPTER HOLDING REGISTER

This is the information that the controller receives from each device. Tables 9L and 10L define the contents of DAHOLD.

2H - DAC STAT

This is the controller register for device status information. Table 11L lists the Hex bit structure for the field.

2I - DEVICE RETRY COUNT

This is the total amount of times that a device has timed-out, over the COAX cable, when the control unit has tried to poll the device. The max count is Hex "FF" which is 256 tries.

STATUS DISPLAY DESCRIPTION

+70 LOCAL STATUS

TABLE 1L

BASE ADDRESS (Switch H5)

*H5 (5-8) must always be "on"

ADDRESS	H5-1	H5-2	H5-3	H5-4
00	ON	ON	ON	ON
10	ON	ON	ON	OFF
20	ON	ON	OFF	ON
30	ON	ON	OFF	OFF
40	ON	OFF	ON	ON
50	ON	OFF	ON	OFF
60	ON	OFF	OFF	ON
70	ON	OFF	OFF	OFF
80	OFF	ON	ON	ON
90	OFF	ON	ON	OFF
A0	OFF	ON	OFF	ON
B0	OFF	ON	OFF	OFF
C0	OFF	OFF	ON	ON
D0	OFF	OFF	ON	OFF
E0	OFF	OFF	OFF	ON
F0	OFF	OFF	OFF	OFF

STATUS DISPLAY DESCRIPTION

+70 LOCAL STATUS

TABLE 2L

HIGHEST DEVICE ADDRESS (Switch F5)

Set to address of last device attached to the controller. Limit must be greater than base address. F5 (1-4) set the same as base chart. If more than 16 devices, set limit to base plus one. (EX: BASE = 80 17 devices Limit = 90)

<u>ADDRESS</u>	<u>F5-5</u>	<u>F5-6</u>	<u>F5-7</u>	<u>F5-8</u>
X0	ON	ON	ON	ON
X1	ON	ON	ON	OFF
X2	ON	ON	OFF	ON
X3	ON	ON	OFF	OFF
X4	ON	OFF	ON	ON
X5	ON	OFF	ON	OFF
X6	ON	OFF	OFF	ON
X7	ON	OFF	OFF	OFF
X8	OFF	ON	ON	ON
X9	OFF	ON	ON	OFF
XA	OFF	ON	OFF	ON
XB	OFF	ON	OFF	OFF
XC	OFF	OFF	ON	ON
XD	OFF	OFF	ON	OFF
XE	OFF	OFF	OFF	ON
XF	OFF	OFF	OFF	OFF

X = Base address or BASE +1 if more than 16 devices.

STATUS DISPLAY DESCRIPTION

TABLE 3L

CUSNS - Control Unit Sense Register

<u>BIT</u>	<u>SWITCH</u>	<u>DEFINITION</u>
80	E1-1	1 = OFF - Reset Retry Count
40	E1-2	0 = ON = CU Selection Option
20	E1-3	Not assigned
10	E1-4	Not assigned
8	E1-5	Not assigned
4	E1-6	Not assigned
2	E1-7	0 = ON = Disable priority print
1	E1-8	0 - ON = Force burst mode

DEFINITION

Reset Retry Count - When this is an 0, all device retries are continually cleared.

CU Selection Option - When enable (on) this allows the CPU to read the status display by issuing a read full buffer to the highest device address on the controller. (A device should not be attached to this address).

Priority Print - When "on" this disables the local priority print but assigned prints can still be initiated.

Force Burst Mode - When enabled this forces burst transfers on a BYTE MUX channel.

STATUS DISPLAY DESCRIPTION

TABLE 4L

STAT - in Tags

<u>BIT</u>	<u>DEFINITION</u>
80	OP - IN
40	ADR - IN
20	STATUS - IN
10	SERVICE - IN
8	METER - IN
4	REQUEST - IN
2	POLL - EN
1	CU - BUSY

DEFINITIONS

POLL-EN - When this is a 1 request-in is not suppressable.

CU - BUSY - When this is a 1, the controller is busy with a task.

STATUS DISPLAY DESCRIPTION

+70 LOCAL STATUS

TABLE 5L

LCR - Last Command Received

<u>Character</u>	<u>Command</u>
01	Write
02	Read full buffer
04	Sense
05	Erase write
06	Read modified
0B	Select
0F	Erase all unprotected

TABLE 6L

SNSBYTE - SENSE BYTE

<u>BIT</u>	<u>APPR.</u>	<u>DEFINITION</u>
80	CR	Command Reject
40	IR	Intervention required
20	BOC	Bus-Out Check
10	EC	Equipment Check
8	DC	Data Check
4	US	Unit Specify
2	CC	Control Check
1	OC	Operation Check

STATUS DISPLAY DESCRIPTION

+70 LOCAL STATUS

TABLE 7L

LAST WCC

<u>BITS</u>	<u>DEFINITION</u>
0, 1	Character reference only
2, 3	00 - Unformatted Print 01 - 40 Character Print Line 10 - 64 Character Print Line 11 - 80 Character Print Line
4	Start Print Bit
5	Sound Alarm Bit
6	Keyboard Restore Bit
7	Reset MDT Bit

TABLE 8L

LAST AID CODE SENT

<u>CODE</u>	<u>FUNCTION</u>	<u>CODE</u>	<u>FUNCTION</u>
60	No Aid display		
E8	No aid Printer		
70	Enter		
F1	PF1	7A	PF10
F2	PF2	7B	PF11
F3	PF3	7C	PF12
F4	PF4	E6	Card Reader
F5	PF5	7E	Lite Pen Attention
F6	PF6	6C	PA1
F7	PF7	6E	PA2 (Encl)
F8	PF8	6B	PA3
F9	PF9	6D	Clear
		F0	Test Req

STATUS DISPLAY DESCRIPTION

+70 LOCAL STATUS

TABLE 9L

DA HOLD

<u>BIT</u>	<u>DEFINITION</u>
80	Device check
40	Transmit check
20	Information Pending
00 - 1F	Aid Code or Printer Status

TABLE 10L

DISPLAY STATION AID CODE

<u>CODE</u>	<u>FUNCTION</u>	<u>CODE</u>	<u>FUNCTION</u>
10	Enter	1A	PF10
11	PF1	1B	PF11
12	PF2	1C	PF12
13	PF3	06	Card Reader
14	PF4	1E	Lite Pen Attention
15	PF5	0C	PA1
16	PF6	0E	PA2 (CNCL)
17	PF7	0B	PA3
18	PF8	0D	Clear
19	PF9	10	Test Req

PRINTER STATION STATUS

<u>BIT</u>	<u>DEFINITION</u>
10	Not Ready
8	(Not Used)
4	Equipment Check
2	Printer Hang
1	(Not Used)

STATUS DISPLAY DESCRIPTION

+70 LOCAL STATUS

TABLE 11L

DAC STAT

<u>BIT</u>	<u>DEFINITION</u>
80	Time out (COAX)
40	Parity Error (from device)
08	Printer
04	Busy
01	480 Buffer

APPENDIX 3

CONTROLLER SPECIAL FEATURES

EXTERNAL TEST SWITCHES AND INDICATORS

Test switches and indicators are included on the front panel of the Remote Controller enabling the operator to perform the following functions:

1. Operate the Controller in normal mode.
2. Operate the Controller in either external loop back test mode or internal loop back test mode.

Test Switches:

1. Start Test (Pushbutton)
2. Test/Normal (Toggle)
3. External/Internal (Toggle)

Indicators:

1. Test Mode
2. Test OK

INTERNAL TEST MODE

To operate the Controller in Internal Test Mode, set the "External/Internal" switch to "Internal" and the "Test/Normal" switch to "Test" and press the "Start Test" pushbutton. The "Test Mode" indicator will illuminate and the "Test OK" indicator will continuously blink.

The controller will remain in Internal Test Mode until the "Test/Normal" switch is returned to the "Normal" position.

EXTERNAL TEST MODE

To operate the Controller in External (loop back) Test Mode, set the "External/Internal" switch to "External" and press "Start Test". The "Test Mode" indicator will illuminate and the "Test OK" indicator will continuously blink.

The Controller will remain in External Test Mode until the "Test/Normal" switch is returned to the "Normal" position.

CAUTION: Testing in External Mode will destroy communication with the host system!

If the test fails in either External or Internal Test Modes, the fault will be indicated by the state of the indicators on the panel. The various failure indications are described in the MAPS descriptions.

TRANSACTION STATISTICS BUFFER FORMAT

In response to a status read command, the Controller will send its entire buffer to the host computer. Included in the buffer content are the transaction statistics for 32 devices. The format for this information is described below.

Definitions:

1. Buffer locations (in hexadecimal) 05A0 to 077F contain all transaction statistics for 32 devices.
2. Buffer locations (in hexadecimal) 05A0 to 05AE contain all transaction statistics for device 00.
3. In reference to the buffer format diagram, the following definitions apply:
 - a. ZODAOXXXXTTTRRR = Transaction Statistics/Device

Where:

- Z = Attribute Code - Protected, non-displayable
- O = Space
- DA = Device address in hexadecimal code
- XXXX = Number of transactions (0-9999 Max)
- TTT = Number of transactions exceeding threshold (0-255 Max)
- RRR = Max response time over all transactions for specific device in seconds (0-255 Max)

LINE 19

1	2	3	4	5	6	7	8	LINE CHAR
12345678901	2345678901	2345678901	2345678901	2345678901	2345678901	2345678901	2345678901	LOCATION
Z	D	A	O	X	X	X	T	TRANS STAT FORMAT
0	0	0	0	0	0	0	0	BUFFER
5	5	5	5	5	5	5	5	ADDRESS
A	A	B	C	D	E	F	G	
0	DEV 00	F	DEV 01	E	DEV 02	D	DEV 03	C
								DEV 04
								B

LINE 20

1	2	3	4	5	6	7	8	LINE CHAR
12345678901	2345678901	2345678901	2345678901	2345678901	2345678901	2345678901	2345678901	LOCATION
X	X	X	T	T	T	T	R	TRANS STAT FORMAT
0	0	0	0	0	0	0	0	BUFFER
5	6	6	6	6	6	6	6	ADDRESS
F	0	1	2	3	4	5	6	
DEV 05	A	DEV 06	9	DEV 07	8	DEV 08	7	DEV 09
								6
								DEV 0A

LINE 21

1	2	3	4	5	6	7	8	LINE CHAR
12345678901	2345678901	2345678901	2345678901	2345678901	2345678901	2345678901	2345678901	LOCATION
T	T	T	R	R	R	Z	O	TRANS STAT FORMAT
0	0	0	0	0	0	0	0	BUFFER
6	6	6	6	6	6	6	6	ADDRESS
4	5	6	7	8	9	0	1	
5	DEV 0B	4	DEV 0C	3	DEV 0D	2	DEV 0E	1
								DEV 0F

LINE 22

1	2	3	4	5	6	7	8	LINE CHAR
12345678901	2345678901	2345678901	2345678901	2345678901	2345678901	2345678901	2345678901	LOCATION
Z	D	A	O	X	X	X	T	TRANS STAT FORMAT
0	0	0	0	0	0	0	0	BUFFER
6	6	6	6	6	6	6	6	ADDRESS
9	9	A	B	C	D	E	F	
0	DEV 10	F	DEV 11	I	DEV 12	D	DEV 13	C
								DEV 14
								B

LINE 23

1	2	3	4	5	6	7	8	LINE CHAR
12345678901	2345678901	2345678901	2345678901	2345678901	2345678901	2345678901	2345678901	LOCATION
X	X	X	T	T	T	T	R	TRANS STAT FORMAT
0	0	0	0	0	0	0	0	BUFFER
6	6	6	7	7	7	7	7	ADDRESS
E	F	0	1	2	3	4	5	
DEV 15	A	DEV 16	9	DEV 17	8	DEV 18	7	DEV 19
								6
								DEV 1A

LINE 24

1	2	3	4	5	6	7	8	LINE CHAR
12345678901	2345678901	2345678901	2345678901	2345678901	2345678901	2345678901	2345678901	LOCATION
T	T	T	R	R	R	Z	O	TRANS STAT FORMAT
0	0	0	0	0	0	0	0	BUFFER
7	7	7	7	7	7	7	7	ADDRESS
3	4	5	6	7	8	9	0	
5	DEV 1B	4	DEV 1C	3	DEV 1D	2	DEV 1E	1
								DEV 1F

The accumulated statistics can be reset by setting the LSB of the WCC character in the status write command.

Example: Reset the statistics, reset status, and set threshold to 2 seconds.
The data sequence is:

STX (Start of Test)
ESC (Escape)
7D (Status Write Command)
F9 (WCC)
C1 (C1 + 1 = 2 seconds)
ETX (End of Text)

The WCC format is:

Bit	
80	0
40	1 Any Value
20	2 Reset Device Retry
10	3 Reset NAKS Sent
8	4 Reset NAKS Received
4	5 Unused
2	6 Unused
1	7 Reset Statistics

READ STATISTICS

To read statistics the read status command is used. Statistics data follows the normal status data. Transaction count is in 4 digit decimal format. Maximum response, in seconds, is in 3 digit decimal format. Exceed threshold value, in seconds, is in 3 digit decimal format.

PROMPTING LINE

GENERAL DESCRIPTION

The Prompting Line is a special feature of the Trivex +70 Display system.

The function of the Prompting Line is to display pertinent messages to the terminal operator in response to certain keyboard activity and to inform the terminal operator that intervention is required where necessary. Cursor position and its relative data content are continuously displayed.

The Prompting Line is considered to be the 25th line in a 24 line terminal but is displayed as the topmost line on the terminal display screen.

The media displayed is arranged in three groups relative to positions in the Prompting Line. The first group is displayed in the leftmost positions, the second group is displayed in the approximate center positions, and the third in the rightmost positions. The groups with their message text are listed:

Group 1

Badge Error

Group 2

Print Pending
Printer Not Rdy
Attn
Attn Pending
Protect Error
Num Fld Error
Insert Error
Insert Badge

Group 3

Cursor Address by Line & Column in Decimal
Cursor Address by Buffer Location in Hex
Data Content (Cursor Location) in Hex

With no error conditions prevailing, no intervention required and no attention functions pending; the Prompting Line will be blank except for cursor location and data content.

FUNCTIONAL DESCRIPTION

ERROR CONDITIONS

The terminal operator is prompted under four distinct error conditions. The prompting message and the relative causes are described:

1. Protect Error

The "Protect Error" message will appear whenever an attempt is made to key any character from the keyboard into a protected field, or when the cursor is positioned in a protected field and the delete key is depressed.

"Protect Error" is extinguished by depressing the reset key on the keyboard.

2. Num Fld Error

The "Num Fld Error" message will appear whenever an attempt is made to key an alpha character from the keyboard into a field designated as "Numeric Only" by the associated attribute character code.

"Num Fld Error" is extinguished by depressing the reset key on the keyboard.

3. Insert Error

The "Insert Error" message will appear whenever an attempt is made, in insert mode, to key a character into a non-protected field when no null characters are present from the cursor position to the next atc, or in the case of an unformatted screen, to the end of page.

"Insert Error" is extinguished by depressing the reset key on the keyboard.

4. Badge Error

The "Badge Error" message will appear whenever the badge reader mechanism detects an invalid code, however, the full badge will be read with error code designations entered in the display buffer for all badge characters in error.

"Badge Error" is extinguished by a keyboard unlock Bit set in the WCC or depressing the reset key on the keyboard, or removal of the badge.

Items 1, 2 and 3 above are listed in their order of priority. Where combinations of designated fields exist, (i.e. a protect numeric only field) and an attempt is made to violate the numeric only precept with an alpha character, the "Protect Error" function will take precedence.

ATTENTION FUNCTIONS

The terminal operator is prompted under three functions where the terminal display unit is waiting to be serviced. The prompting message and the related functions are described:

1. Print Pending

The "Print Pending" message will appear under an assigned printer condition when the assigned printer is busy printing its buffer or a priority print condition when all printers are busy printing.

"Print Pending" will extinguish when the printer accepts the terminal buffer data.

2. Attn Pending

The "Attn Pending" message will appear whenever the 'Enter', 'Clear', 'PA1', 'PA2', 'PA3', or any 'PF' key is depressed on the keyboard and only after a valid badge has been read and is still captive in the Badge Reader, and the host computer has returned a WCC with unlock keyboard.

The "Attn Pending" message will also appear after a badge has been inserted in the Badge Reader and it's data has been entered into the display buffer.

"Attn Pending" will extinguish when the host computer returns a WCC with unlock keyboard.

3. Attn

The "Attn" message will appear when an Attn Pending has been polled and no unlock keyboard has been sent by the host computer.

INTERVENTION REQUIRED FUNCTIONS

The terminal operator is prompted under two conditions which require intervention:

1. Insert Badge

The "Insert Badge" message will appear if no badge is in the Badge Reader.

2. Printer Not Rdy

The "Printer Not Rdy" message will appear whenever a print function is initiated and the Printer or Printer Controller is powered off, the Printer is not selected or out of paper, or no Printer assignment has been made.

CURSOR ADDRESS AND DATA CONTENT PROMPTING

Four sub groups (XX, YY, ZZZ, DD) are displayed in the rightmost locations of the Prompting Line which contain:

XX = Cursor Line Location (1-24) in Decimal

YY = Cursor Column Location (1-80) in Decimal

ZZZ = Cursor Buffer Location (000-77F) in Hex

DD = Data Content at Cursor

The cursor location is continuously displayed by screen line number and line character location, in decimal notation, as is the display buffer location in hexadecimal notation.

The data content is continuously displayed in hexadecimal notation relative to the cursor except in non-display fields where no data content is displayed.